

## KRAL pumps/ pump units/pump stations

Series C, F, G, K, L, M, N, R, W, DKC, DLC, DS3/4 (ATEX design)  
Equipment category: 3G/3D for use in zones 2 and 22.



Observe notes and regulations for use in potentially explosive areas.

OIX 05en-GB  
Edition 2025-11  
Original instructions

<b>1 About this document</b> .....	<b>3</b>
1.1 General information.....	3
1.2 Associated documents .....	3
1.3 Scope .....	3
1.4 Target groups .....	3
1.5 Scope of the ATEX certification.....	4
1.6 Symbols.....	5
1.6.1 Danger levels .....	5
1.6.2 Danger signs.....	5
1.6.3 Symbols in this document .....	5
<b>2 Safety</b> .....	<b>6</b>
2.1 Potentially explosive atmosphere.....	6
2.2 Intended use in potentially explosive atmospheres in compliance with Directive 2014/34/EU .....	6
2.3 Foreseeable misuse .....	7
2.4 Materials and liquids.....	7
2.5 Limits for surface temperatures.....	7
2.6 Evaluation of pump units and pump stations.....	8
2.7 Additional obligations of the operator-owner when used in potentially explosive areas.....	9
2.8 Safety instructions .....	10
2.8.1 Additional safety instructions for use in potentially explosive areas.....	10
2.8.2 Dangers at magnetic coupling systems .....	10
2.8.3 Expiration of the ATEX approval.....	10
2.8.4 Ignition sources in normal operation .....	11
<b>3 Identification</b> .....	<b>12</b>
3.1 ATEX marking .....	12
<b>4 Installation, removal</b> .....	<b>13</b>
4.1 Installing and connecting.....	13
4.1.1 Unpacking the product.....	13
4.1.2 Checking the explosion protection identification .....	13
4.1.3 Checking the conditions of use.....	13
4.1.4 Perform basic measures .....	13
<b>5 Operation</b> .....	<b>14</b>
5.1 Commissioning.....	14
5.1.1 Perform basic measures .....	14
<b>6 Maintenance and Servicing</b> .....	<b>14</b>
6.1 Safety during maintenance and servicing .....	14
6.2 Perform basic measures .....	14
6.3 Additional required maintenance in case of use in potentially explosive areas .....	15
6.4 Maintaining the pump .....	15

## 1 About this document

### 1.1 General information

These instructions are only valid in conjunction with the operating instructions for the pump/pump unit. They must be observed if the pump/pump unit is used in potentially explosive areas.

As with the operating instructions of the pump/pump station, these supplementary instructions form part of the product, must be read carefully and kept for future reference.

### 1.2 Associated documents

- Pump/pump unit operating instructions
- Pump/pump unit design data sheet
- Pump/pump unit material data sheet
- Operating instructions and technical data sheet of the drive technology and sensors supplied, if applicable

### 1.3 Scope

- C series screw pumps/pump units
- F series screw pumps/pump units
- G series screw pumps/pump units
- K series screw pumps/pump units
- L series screw pumps/pump units
- M series screw pumps/pump units
- N series screw pumps
- R series screw pumps/pump units
- W series screw pumps/pump units
- DKC series pump stations
- DLC series pump stations
- DS3/4 series pump stations

### 1.4 Target groups

The instructions are intended for the following persons:

- Persons who work with the product
- Operator-owners who are responsible for the use of the product

Persons who work with the product must be qualified. The qualification ensures that possible dangers and material damage that are connected to the activity are detected and avoided. These persons are qualified personnel who carry out the work properly due to their training, knowledge and experience and on the basis of the relevant provisions.

Information on the required qualification of the personnel is provided separately at the beginning of the individual chapters in these instructions. The following table provides an overview.

Target group	Activity	Qualification
Transport personnel	Transporting, unloading, setting up	Qualified personnel for transport, mobile crane operators, crane operators, forklift operators
Fitter	Mounting, connection	Qualified personnel for mounting
Electrician	Electrical connection	Qualified personnel for electric installation

## 1 About this document

### 1.5 Scope of the ATEX certification

Target group	Activity	Qualification
Trained personnel	Delegated task	Personnel trained by the operator-owner who know the task delegated to them and the possible dangers arising through improper behaviour.
Expert for work in potentially explosive areas	Operation, maintenance, servicing	Qualified personnel who because of their vocational training, training and experience, is qualified to recognize risks and possible hazards when working on the device or subcomponents in potentially explosive areas and is able counteract these by taking suitable measures.  This qualified personnel has knowledge of different ignition protection types, installation procedures and zoning divisions.  This qualified personnel is familiar with rules and regulations that are relevant for the activity and explosion protection, in particular with the ATEX Directives 2014/34/EU and 1999/92/EC.

Tab. 1: Target groups

### 1.5 Scope of the ATEX certification



The manufacturer is only responsible for material and equipment supplied, which have been selected on the basis of the data for the operating conditions provided by the customer or end user. These data are listed in the order confirmation. If in doubt, please contact the manufacturer.

Included in delivery	ATEX certification
Pump with free shaft end	<input type="checkbox"/> Explosion protection marking on the pump data plate applies solely to the pump. <input type="checkbox"/> Any additional equipment attached must have separate certification to at least the same level of protection as the pump. The supplier(s) of this equipment is/are responsible for providing this equipment. <input type="checkbox"/> The entire unit/pump unit must be certified separately by the creator of the overall configuration. The unit must be marked with its own data plate, which is provided by the creator of the overall configuration.
Pump unit	<input type="checkbox"/> Explosion protection marking on the pump data plate applies to the entire unit/pump assembly.
Pump station	<input type="checkbox"/> Explosion protection marking on the pump station data plate applies to the entire unit/pump station.







Tab. 2: Scope of ATEX certification

## 1.6 Symbols







### 1.6.1 Danger levels

	Signal word	Danger level	Consequences of non-observance
	DANGER	Immediate threat of danger	Serious personal injury, death
	WARNING	Possible threat of danger	Serious personal injury, invalidity
	CAUTION	Potentially dangerous situation	Slight personal injury
	ATTENTION	Potentially dangerous situation	Material damage

### 1.6.2 Danger signs

	Meaning	Source and possible consequences of non-observance
	Potentially explosive atmosphere	Explosion or fire through potentially explosive atmosphere
	Electrical voltage	Electrical voltage causes serious physical injury or death.
	Raised load	Falling objects can result in serious physical injury or death.
	Heavy load	Heavy loads can result in serious back problems.
	Risk of slipping	Discharging pumped liquid and oils on the foundation or tread surfaces can cause falls with serious physical injury or death.
	Flammable substances	Discharging pumped liquid and oils can be easily inflammable and can result in serious burns.
	Hot surface	Hot surfaces can cause burns.

### 1.6.3 Symbols in this document

	Meaning
	Warning personal injury
	Safety instruction
	Prohibition sign cardiac pacemaker
	Request for action
	Multi-step instructions for actions
	Action result
	Cross-reference

## 2 Safety

### 2.1 Potentially explosive atmosphere

## 2 Safety

### 2.1 Potentially explosive atmosphere

A potentially explosive atmosphere is a mixture with air, under atmospheric conditions, of flammable substances in the form of gases, vapours, mists or dusts in which, after ignition has occurred, combustion spreads to the entire unburned mixture.

### 2.2 Intended use in potentially explosive atmospheres in compliance with Directive 2014/34/EU

The intended use of the three-spindle screw pumps and pump stations is the continuous, directional delivery of non-abrasive, exclusively liquid media.

ATEX screw pumps and pump stations are category 3G/3D outdoor equipment (outside the pump). This means that they can be used in potentially explosive gas atmospheres of Zone 2 or in potentially explosive dust atmospheres of Zone 22.

Atmosphere	Explosion subgroup		Category / EPL	
	Inside the pump	Outside the pump	Inside the pump	Outside the pump
Gas	–	IIC	–	3 / Gc
Dust	–	IIIC	–	3 / Dc

Tab. 3: Possible areas of application

Zone	Interval (annual)	Interval (differentiated)	Dwell time
2 (gas)	> 1 – 10 times	> 1 time/year	< 0.5 h
22 (dust)		< 1 time / month	

Tab. 4: Occurrence of a mixture

In addition to the frequencies of occurrence according to the above table, it should be noted that an ignitable mixture may only be present for less than 50% of the operating time.

#### Special conditions

The following special conditions must be observed:

- For complete pump units, use in and on potentially explosive atmospheres may be restricted to exclusively gas explosive atmospheres, zone 2. Observe the Ex marking on the product.
- Before commissioning, the pump, pump unit or pump station must be included in the equipotential bonding of the entire system.
- For safety reasons the operator must avoid simultaneous delivery of medium and air, so that it can always be assumed that there is no zone inside the pump. Commissioning as well as start-up and shut-down procedures must be taken into account.
- The response of the ignition source monitoring must result in a safe shutdown of the drive motor.
- Equipment for supplying the temperature monitoring must be intrinsically safe.
- The temperature class of the pump/pump unit is determined by the pumped medium.
- Interactions between the pumped medium and the pump materials must be taken into account by the operator.
- The maximum permissible medium temperature according to the type plate must not be exceeded at any time.
- The operation of the pump can cause electrostatic charging of flowing liquids.
- For use in explosion subgroup IIC, only medium and high conductivity media ( $\leq 50 \text{ pS/m}$  at  $50 \cdot 10^{-12} \text{ S/m}$ ) may be pumped.
- For use in explosion subgroups IIB and IIA, media with low conductivity ( $> 50 \text{ pS/m}$  at  $50 \cdot 10^{-12} \text{ S/m}$ ) may also be conveyed. (TRGS 727)
- Dust accumulation on the outside  $> 5 \text{ mm}$  must be excluded by the operator.
- The permissible ambient temperature range is explicitly marked on the data plate if it deviates from a range of  $-20^\circ\text{C}$  to  $+40^\circ\text{C}$ .
- The restrictions/limitations with regard to reversible operation must be observed.

### 2.3 Foreseeable misuse

The following misuse of the pump/pump unit/pump station is prohibited:

- Use of the pump/pump unit or pump station in an area with a higher ATEX category than that specified for the equipment concerned, e.g. use of a category 2 item of equipment in a category 1 system
- Operation under ambient conditions that deviate from the conditions specified in the section "Checking the operating conditions" of these supplementary instructions ↘ Installation, removal, Page 13
- Reversible operation of the pump without compliance with the restrictions/limitations for reversible operation
- Pumping air contaminated with ignitable or explosive dusts and operating the pump in such environments
- Pumping pyrophoric substances
- Operation with substances whose self-ignition temperatures are below the defined temperature rating

### 2.4 Materials and liquids

Interactions between the pumped liquid and the materials of the pump have to be considered by the operator-owner.

Ensure in particular that ...

- All accessories are conductive.
- The pump is not used for liquids which can form an explosive atmosphere under normal atmospheric conditions or process conditions.

### 2.5 Limits for surface temperatures

The standard ISO 80079-36 defines the permissible limits for surface temperatures. It differentiates between gases/vapours and dusts.

For gases and steams the devices are divided into temperature classes.

Temperature class	Max. surface temperature [°C]	Temperature range for mixtures [°C]	Typical gas (selection)
T1	450	> 450	I: Methane II A: Acetone, methane, methanol, propane II B: Town gas II C: Hydrogen
T2	300	> 300 – ≤ 450	II A: Ethyl alcohol, n-butane II B: Ethylene II C: Acetylene
T3	200	> 200 – ≤ 300	II A: Diesel, fuel oils II B: Hydrogen sulphide
T4	135	> 135 – ≤ 200	II A: Acetaldehyde, ethyl ether
T5	100	> 100 – ≤ 135	–
T6	85	> 85 – ≤ 100	II C: Sulphur hydrocarbon

Tab. 5: Limit temperatures for gases and vapours

## 2 Safety

### 2.6 Evaluation of pump units and pump stations

For dusts the maximum permissible surface temperature of the device is specified instead of the temperature class, as in this case a safety gap between the surface temperature and the ignition temperature must also be observed.

The permissible surface limit temperature is based on the two values determined from processes A and B of IEC 50281-2-1:

Limit temperature = MIN (value A - 75 °C) and (value B x 2/3)

Dust (selection)	IEC 50281-2-1 Process A [°C]	IEC 50281-2-1 Process B [°C]	Max. permissible surface limit temperature [°C]
Wood flour	300	400	225
Cellulose	370	500	295
Lignite	225	380	150
Soot	385	620	310
Sulphur	280	280	186
Aluminium	280	530	205

Tab. 6: Limit temperatures for dusts from device group II

### 2.6 Evaluation of pump units and pump stations

Combinations of motors and pumps into pump units as well as pump stations are to be considered a "group of individual devices". In accordance with Section 3.7.5 of the ATEX Directive the manufacturer of a group of individual devices can assume that the latter fulfils the Directive if a corresponding Declaration of Conformity exists. This applies in particular for couplings and motors that are "equipment" in the sense of the Directive. In addition for further components that are used, for example, in the station construction (flow indicators/dry running protection, pressure switches, etc.). For further information on this topic please refer to the corresponding documentation of these devices.

The manufacturer of a group of individual devices solely verifies whether further dangers arise through the final combination of the components. This is not the case at the pump units and pump stations manufactured by KRAL. In accordance with the Directive there is therefore no need for a further evaluation of conformity or for an overall identification of this group of individual devices.

### 2.7 Additional obligations of the operator-owner when used in potentially explosive areas

When the product is used in potentially explosive areas the operator-owner has to observe the following additional obligations from the ATEX directive (minimum regulations for improving the health protection and the safety of the employees that can be endangered through potentially explosive atmospheres).

This results in the following additional obligations for the operator-owner:

Phase in life cycle	Obligations of the operator-owner
Project planning, selection and erection	Design electrical installations in hazardous areas according to EN 60079-14: <ul style="list-style-type: none"> <li><input type="checkbox"/> Explosion protection principles</li> <li><input type="checkbox"/> Ignition protection types, device marking</li> <li><input type="checkbox"/> Tests according to EN 60079-17</li> </ul>
All phases	<ul style="list-style-type: none"> <li><input type="checkbox"/> Evaluating and documenting explosion hazards for operating ranges of the plant in accordance with Directive 2014/34/EU Annex I.</li> <li><input type="checkbox"/> Compliance with Directive 1999/92/EC on health protection and safety of employees in potentially explosive atmospheres.</li> <li><input type="checkbox"/> Ensure that the specifications on the rating plate match the system data.</li> <li><input type="checkbox"/> Operate pump solely in accordance with ATEX marking.</li> <li><input type="checkbox"/> Ensure that motors, couplings and monitoring devices provided by the customer comply with the category and temperature class in the respective zone.</li> <li><input type="checkbox"/> Observe the data sheet supplied with the pump.</li> <li><input type="checkbox"/> Observe the instructions supplied with the supplier components, e.g. explosion-protected motor, coupling, ...</li> <li><input type="checkbox"/> Inform personnel about special hazards, e.g. explosion hazard when removing dust deposits.</li> </ul>
Operation	The following aspects have to be ensured at all times: <ul style="list-style-type: none"> <li><input type="checkbox"/> Pump earthed</li> <li><input type="checkbox"/> No contact between coupling and coupling protection</li> <li><input type="checkbox"/> The interior of the pump, seal chamber, auxiliary systems and suction line/pressure line must always be completely filled with pumped liquid; the pump chamber is a special case: according to the intended use described in Section 2.2 and the required category, an ignitable mixture may be present inside the pump for a limited period of time.</li> <li><input type="checkbox"/> Permissible surface temperature at the pump observed</li> <li><input type="checkbox"/> Fittings on suction side and pressure side set correctly</li> <li><input type="checkbox"/> Pump regularly maintained and monitored</li> <li><input type="checkbox"/> Dry running of the pump excluded, e.g. by level monitoring, flow measurement, flow monitor; this only applies for a period longer than described in Section 2.2 for the required category.</li> </ul>
Maintenance and Servicing	<ul style="list-style-type: none"> <li><input type="checkbox"/> Ensure that work is only carried out by authorised qualified personnel who ...               <ul style="list-style-type: none"> <li>▪ Are familiar with standards and regulations for devices for use in potentially explosive areas.</li> <li>▪ Have the required knowledge when handling devices for use in potentially explosive areas.</li> </ul> </li> <li><input type="checkbox"/> After performing maintenance and servicing, the pump unit for operation may only be approved by authorised personnel, by an officially recognised person or by the pump manufacturer.</li> </ul>
Substantial modification	Ensure that after significant modifications to the pump unit, such as modifications to the sealing materials, seal designs, secondary seals, hydraulics... <ul style="list-style-type: none"> <li><input type="checkbox"/> A new ignition hazard assessment is performed.</li> <li><input type="checkbox"/> The pump unit is checked in accordance with state of the art and the requirements of Directive 2014/34/EU.</li> <li><input type="checkbox"/> The changes are documented in the explosion protection document of the operator-owner in accordance with Directive 1999/92/EC or in the conformity assessment procedure in accordance with Directive 2014/34/EU through the issue of a Declaration of Conformity.</li> </ul>

Tab. 7: Obligations of the operator-owner when used in potentially explosive areas

#### 2.8 Safety instructions

##### 2.8.1 Additional safety instructions for use in potentially explosive areas



#### **DANGER**

##### **Loss of explosion protection can result in death.**

The temperature class shall be determined by the planner/operator. The actual maximum surface temperature in normal operation of the pump, and hence the temperature class, is essentially dependent on the inlet temperature of the pumped liquid. The maximum permissible temperature of the pumped liquid, depending on the specific temperature class, is explicitly stated on the data plate.

- ▶ Ensure that the maximum permissible medium temperature according to the data plate on the pressure-side process connection is constantly monitored.
- ▶ Use flow monitor/dry-running protection to switch off immediately in a safety-oriented manner in the event of dry running.
- ▶ If the maximum permitted liquid temperature as per the data plate is exceeded, the pump unit must be switched off immediately.

##### 2.8.2 Dangers at magnetic coupling systems

Magnetic fields from magnetic coupling systems (MCS) can influence the function and operational safety of electrical and electronic devices. The following safety instructions must be observed.



#### **The following safety instructions must be observed:**

- Keep the MCS away from cardiac pacemakers. There is a danger to life!
  - Under no circumstances may persons with cardiac pacemakers perform installation, dismantling or maintenance work.
- Persons with cardiac pacemakers must comply with the following safe distances to the MCS:
  - 3 m distance to the openly accessible MCS
  - 1 m distance to pump units with installed MCS
- Do not bring the MCS in the immediate area of PCs, data carriers and other electronic components.
- Keep the MCS away from clocks, magnetized tools and measuring equipment as well as all magnetizable parts.
- Do not bring both the MCS parts together, as this can destroy the magnetic coupling system.

##### 2.8.3 Expiration of the ATEX approval

The ATEX approval for the pump/pump unit or pump station will be invalidated through ...

- Improper use
- Unauthorised modifications
- Use of non-original spare parts
- Use of non-specified equipment
- Failure to observe these supplementary instructions and the applicable documents
- Failure to comply with the prescribed maintenance intervals/maintenance intervals

### 2.8.4 Ignition sources in normal operation

The table lists possible ignition sources in accordance with EN 1127-1.

Ignition sources in normal operation	Causes and protective measures
Hot seal housing surface	Possible causes: <input type="checkbox"/> Operational heating due to relative movement on the sliding surfaces of the mechanical seal / radial shaft seal ring as well as leakage which can result in an ignitable mixture.  <input checked="" type="checkbox"/> Ensure that the mechanical seal manufacturer has provided mathematical proof of the suitability of the mechanical seal for the specific order (required temperature class) and that it bears the relevant CE mark.
Pump housing hot surface	Possible causes: <input type="checkbox"/> Abrasive particles in the pumped medium cause surface damage. Surface damage leads to strong local heating due to increased friction values.  <input checked="" type="checkbox"/> Always use a suction filter with a maximum mesh size of 0.5 mm.
Electrostatics	Possible causes: <input type="checkbox"/> Electrostatic effect of the insulating lacquer layer <input type="checkbox"/> Signs for electrostatics <input type="checkbox"/> Delivery of non-conductive liquids  <input checked="" type="checkbox"/> Ensure that the coating thickness of the paint does not exceed 2 mm. <input checked="" type="checkbox"/> Use non-conductive signs with an area < 10000 mm <sup>2</sup> . <input checked="" type="checkbox"/> Always integrate the pump into the potential equalisation of the system. <input checked="" type="checkbox"/> Refer to TRGS 727 when handling liquids of different conductivity in potentially explosive atmospheres.
Lightning	The installation of the pump/pump unit or pump station is permitted both indoors and outdoors.  <input checked="" type="checkbox"/> Equip the hazardous area with lightning protection on the operator side.
Electromagnetic waves in the frequency range $3 \times 10^{11} - 3 \times 10^{12}$ Hz	In particular, the focussing of sunlight, for example, can cause ignition in this spectral range through absorption on solid surfaces.  <input checked="" type="checkbox"/> In the case of direct sunlight (outdoor installation), suitable shading must be provided by the operator.

Tab. 8: Ignition sources in normal operation

The use of pumps with an EU Declaration of Conformity to Directive 2014/34/EU is permissible in Ex-Zone 2 and 22 ("safe in normal operation") without further protective measures.

**Note** The maximum surface temperatures on the pump and its components to be expected during normal operation are determined by the temperature and viscosity of the pumped medium, motor speed and differential pressure of the pump. The maximum permissible liquid temperature is shown on the data plate.

## 3 Identification

### 3.1 ATEX marking

Screw pumps that are intended for correct use in potentially explosive areas have the ATEX marking in addition to the data plate.

This information on explosion protection labelling is generally valid. The temperature class and type of protection are documented on the explosion protection label on the pump. The marking on the pump as non-electrical equipment according to Directive 2014/34/EU applies to the specified pump-motor combination. The motors supplied comply with the Directive and are tested and labelled. If the pump is supplied without a motor, the attached marking applies only to the pump. In this case, it is the responsibility of the operator to fit the pump with a motor in accordance with Directive 2014/34/EU.

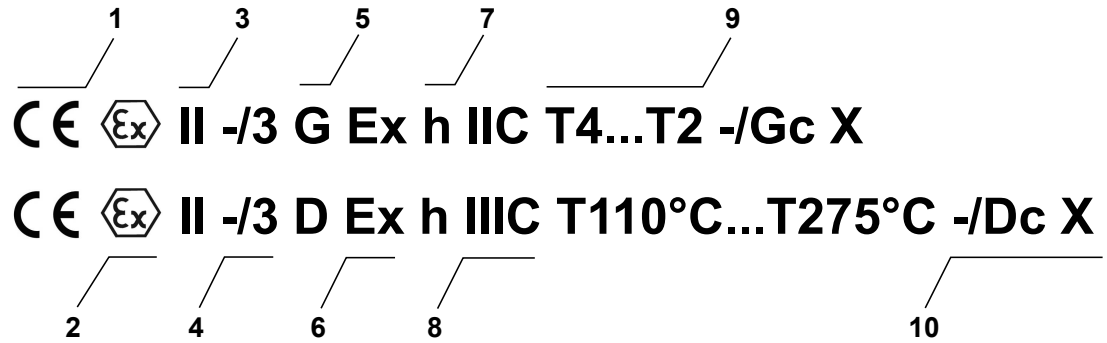

Fig. 1: ATEX marking

1	CE mark	6	Ex symbol
2	Symbol for explosion-protected equipment	7	Type of protection (here h)
3	Equipment group according to RL 2014/34/EU	8	Equipment group with subgroup
4	Equipment category according to RL 2014/34/EU	9	Temperature class range
5	Ex-atmosphere	10	Equipment Protection Level (EPL)

The conformity classification applies to the pump/pump unit or pump station under the "usual atmospheric conditions" as defined in EN ISO 80079-36:2016:

Parameter	Unit	Value
Ambient temperature range	[°C]	-20 ... 40
Ambient pressure range	[bar]	0.8 – 1.1
Oxygen content of the air	[%]	21

## 4 Installation, removal

### 4.1 Installing and connecting

The measures during installing and connecting of the pump/pump station depend on the category.

#### 4.1.1 Unpacking the product



#### DANGER

##### Risk of explosion due to static charging of the packaging film.

- ▶ Remove packaging film only outside the potentially explosive atmosphere, i.e. before the product is transported into the potentially explosive atmosphere.

Requirement:

- ✓ Product outside the potentially explosive area
- ▶ Remove the packaging material and dispose of in accordance with the locally applicable regulations.

#### 4.1.2 Checking the explosion protection identification

- ▶ Compare the explosion protection identification at the pump with the specifications in the ATEX Declaration of Conformity and ensure that both specifications correspond with the explosion protection requirements at the installation location.

#### 4.1.3 Checking the conditions of use

- ▶ Checking ambient conditions:
    - Ambient temperature  $-20\text{ °C} \dots +40\text{ °C}$
    - Seals and lubricants are resistant to all vapours, gases and dusts occurring at the point of use
  - ▶ Check temperature of the pumped liquid:
    - For the permissible temperature range of application see the rating plate
  - ▶ Check properties of the pumped liquid:
    - Does not contain solids
    - Does not form an explosive atmosphere under normal atmospheric conditions or under process conditions
    - Chemically stable (does not tend to disintegrate exothermically or under pressure under conditions of use and ambient conditions)
    - Not ignitable under exclusion of oxygen
  - ▶ Check requirements at the installation location:
    - Free air supply to pump and motor
    - Earthing connection available
- ⇒ The pump/pump unit must not be used in case of deviating conditions of use.

#### 4.1.4 Perform basic measures

- ▶ Check that the pump and motor are suitable for use in the selected area ↪ Identification, Page 12.
- ▶ For inverter operation:
  - Only use motors that are approved for this operating mode.
  - Ensure that the nominal speed of the pump is maintained, see data sheet.
  - Motor must be approved for ATEX operation with inverter.
  - Observe standards and regulations for installation and operation with an inverter.
- ▶ For a pump with motor provided by the operator:
  - The motor must meet the requirements (group, category) of the hazardous area.
  - If a frequency inverter is used, the motor must be suitable for this application.
- ▶ Observe the operating instructions for the motor, coupling and monitoring devices.
- ▶ For coupling with contact protection:
  - Only use contact protection with electrically conductive components.
- ▶ Prevent foreign bodies from being sucked in, for example with a separator or start-up sieve.
- ▶ Install leakage monitoring that complies with the requirements of Directive 2014/34/EU.
- ▶ Protect the pump from knocks and falling metal objects.

## 5 Operation

### 5.1 Commissioning

#### 5.1.1 Perform basic measures

1. ➤ Ensure that the pump is completely filled and vented.
2. ➤ Observe the operating instructions for the motor, coupling and monitoring devices.
3. ➤ Coordinate every operation of the pump (including test run) with the operator.
4. ➤ After an emergency stop, only allow authorised personnel to carry out recommissioning.
5. ➤ Observe the maximum permissible temperature of the pumped medium.

## 6 Maintenance and Servicing

### 6.1 Safety during maintenance and servicing



#### DANGER

##### Explosion hazard through explosive vapours of the pumped medium.

- ▶ Let pumps cool before maintenance work and servicing work.
- ▶ Drain the pump before maintenance work and servicing work and flush if necessary.
- ▶ Collect any discharging pumped medium safely and dispose of it in accordance with the applicable regulations.



#### DANGER

##### Non-suitable spare parts can result in explosions.

- ▶ Always replace worn parts with original spare parts.



#### DANGER

##### Explosion hazard from sparks when the components of the magnetic coupling collide.

- ▶ Always use a positive guide when carrying out assembly work on pumps with magnetic coupling.
- ▶ Always carry out assembly work outside the potentially explosive area.
- ▶ Alternatively, eliminate the potentially explosive atmosphere for the duration of the assembly work, e.g. by extraction or ventilation.



#### DANGER

##### Magnetic field.

Risk of death for persons with cardiac pacemaker, metallic implant or neurostimulator.

- ▶ Under no circumstances may persons with cardiac pacemakers, metallic implant or neurostimulator perform work on the pump/pump unit.

#### 6.2 Perform basic measures

1. ➤ Remove dust deposits according to operator specifications.
2. ➤ Remove metal chips and deposits on and under the coupling guard.
3. ➤ Observe the operating instructions for the motor, coupling and monitoring devices.
4. ➤ As a precaution, replace pump roller bearings with lifetime lubrication in category 2 applications every 8000 hours.
5. ➤ Change the motor roller bearings according to the manufacturer's instructions.

## 6.3 Additional required maintenance in case of use in potentially explosive areas

6. ➤ Check at appropriate intervals:
- Engine and coupling according to the manufacturer's operating instructions
  - Deformation of the coupling guard and distance to rotating parts
  - Function of the monitoring devices
  - Tightness of the suction line

## 6.3 Additional required maintenance in case of use in potentially explosive areas

**Note** Test intervals have to be specified for the entire operating life in accordance with the applicable national laws on occupational safety laws. Tests and checks have to be carried out at least once a year.

1. ➤ Perform maintenance in accordance with the operating instructions of the pump/pump station.
2. ➤ Observe additional maintenance required.

Component	Maintenance required	Cycle
Bearings	<input type="checkbox"/> <b>Essential:</b> Replace the bearings!	8000 h
Bearings	<input type="checkbox"/> Check for noise and vibration <b>Warning:</b> If any abnormalities are found, replace bearings immediately	4 weeks
Level monitoring/flow monitoring	<input type="checkbox"/> Functional test	4 weeks
Temperature sensors (surface of pump housing/containment can, receiver medium)	<input type="checkbox"/> Functional test	4 weeks
Mechanical seal with receiver	<input type="checkbox"/> Check the fill level of the receiver	2 weeks
	<input type="checkbox"/> Vent the sealing chamber	4 weeks

Tab. 9: Additional maintenance required

**Note** Maintenance intervals are shortened under difficult operating conditions or when being used in an aggressive environment.

## 6.4 Maintaining the pump

Personnel qualification:	<input type="checkbox"/> Fitter
Personal protective equipment:	<input type="checkbox"/> Work clothing <input type="checkbox"/> Face protection <input type="checkbox"/> Protective gloves <input type="checkbox"/> Protective helmet
Aids:	<input type="checkbox"/> Positive guide

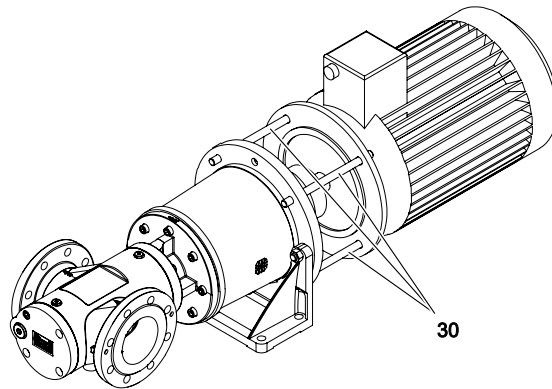

1. ➤ Use a positive guide **30** for all maintenance work on the pump with magnetic coupling.
2. ➤ Carry out maintenance in accordance with the pump operating instructions.



# KRAL

